

AB32VG1

Audio Player Microcontroller

Versions: 0.0.2

2019/02/25

Declaration

Copyright © 2019, www.bluetrum.com.

All Rights Reserved. No Unauthorized Distribution.

Bluetrum reserves the right to make changes without further notice to any products herein to improve reliability, function or design.

For further information on the technology, product and business term, please contact Bluetrum Company.

For sales or technical support, please send email to the address:

Sales: sales@bluetrum.com

Technical: project@bluetrum.com

Revision History

Date	Version	Comments	Revised by
2018-09-27	0.0.1	First draft	Leo
2019-02-25	0.0.2	1.modify some misdescription	Leo

Table of Contents

TABLE OF CONTENTS.....	3
1 PRODUCT FEATURES.....	4
2 PACKAGE DEFINITION.....	5
2.1 PIN ASSIGNMENT.....	5
2.2 PIN DESCRIPTIONS.....	6
3 CHARACTERISTICS.....	10
3.1 PMU PARAMETERS.....	10
3.2 IO PARAMETERS.....	10
3.3 AUDIO DAC PARAMETERS.....	11
3.4 AUDIO ADC PARAMETERS.....	11
3.5 BT PARAMETERS.....	11
3.6 CURRENT PARAMETERS.....	12
4 PACKAGE INFORMATION.....	13

1 Product Features

CPU and Flexible IO

- ✚ 32bit High performance CPU with DSP instruction
- ✚ Program memory: internal 8M bit flash
- ✚ Flexible GPIO pins with Programmable pull-up and pull-down resistors;
- ✚ Support GPIO wakeup or interrupt;

Bluetooth Radio

- ✚ Compliant to Bluetooth 5.0 and BLE specification (QDID: [115952](#));
- ✚ TX output power +2dBm in typical;
- ✚ RX Sensitivity with -90.5dBm @Basic Rate;

FM Tuner

- ✚ Support frequency band 76~108MHz;
- ✚ Auto search tuning;
- ✚ Programable de-emphasis(50/75uS);
- ✚ Receive signal strength indicator (RSSI);

Audio Interface

- ✚ Audio codec with 16bit stereo DAC and two channel 16bit ADC;
- ✚ Support flexible audio EQ adjust;
- ✚ Support Sample rate 8, 11.025, 12, 16, 22.05, 32, 44.1 and 48KHz;
- ✚ 4 channel Stereo Analog MUX;
- ✚ Two channel MIC amplifier input;
- ✚ High performance Stereo audio ADC with 90dB SNR;
- ✚ High performance Stereo audio DAC with

95dB SNR, with headphone amplifier output;

Peripheral and Interfaces

- ✚ Three 32-bit timers;
- ✚ Three multi-function 32-bit timers, support Capture and PWM mode;
- ✚ WatchDog;
- ✚ Three full-duplex UART;
- ✚ Two SPI;
- ✚ IR controller;
- ✚ SD Card Host controller;
- ✚ SPDIF receiver;
- ✚ Audio interface IIS;
- ✚ Full speed USB 2.0 HOST/DEVICE controller;
- ✚ Sixteen Channels 10-bit SARADC;
- ✚ Integrate IRTC;
- ✚ Build in PMU, such as charger/buck/LDO;

Package

- ✚ LQFP48;

Temperature

- ✚ Operating temperature: -40°C to +85°C;
- ✚ Storage temperature: -65°C to +150°C ;

2 Package Definition

2.1 Pin Assignment

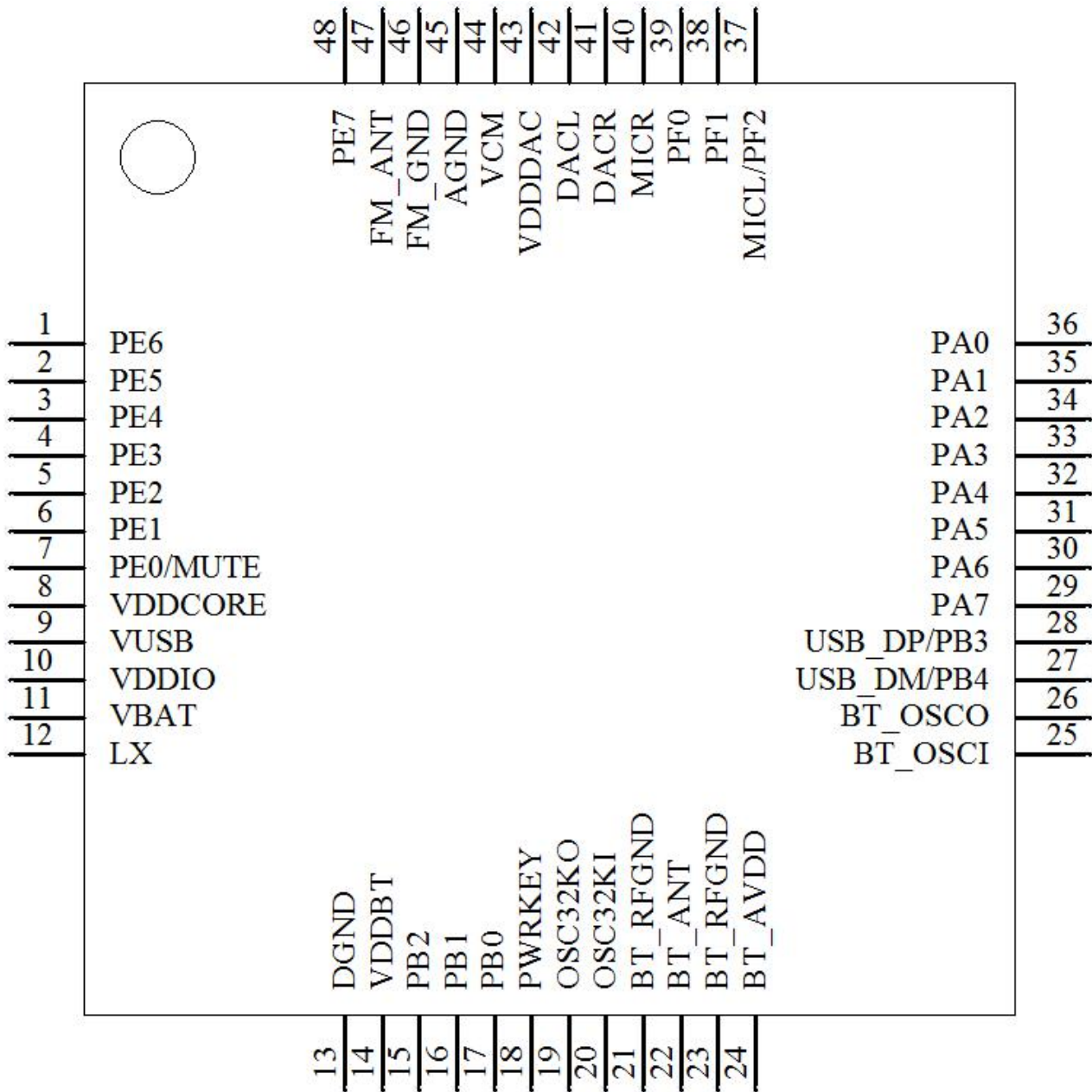

Figure 2- 1 Pin assignment for LQFP48

2.2 Pin Descriptions

Table 2- 1 LQFP48 pin description

Pin No.	Name	Type	Function
1	PE6	I/O	ADC8 AUXL2 SPDIF4 SDCLK-G3 SPI1CLK-G4 RX0-G4 HSTRX-G9 FMOSC-G6 LPWM2-G1 TMR3CAP_G7/IR_G7 PE6
2	PE5	I/O	ADC7 SPDIF3 SDCMD-G3 SPI1DI-G4 FMOSC-G5 LPWM1-G1 TMR3CAP_G6/IR_G6 PE5
3	PE4	I/O	SPI0DI-G2 SPI1DI-G6 LPWM0-G1 IISMCLK-G2 PE4
4	PE3	I/O	SPI0CLK-G2 SPI1CLK-G6 TX2-G1 PWM2-T5 IISLRCLK-G2 PE3
5	PE2	I/O	SPI0DO-G2 SPI1DO-G6 RX2-G1 PWM1-T5 IISCLK-G2 PE2
6	PE1	I/O	RX0-G6 PWM0-T5 IISDO-G2 PE1
7	PE0	I/O	SPI0DI-G3

			TX0-G6 LPWM2-G2 IISDI-G2 TMR3CAP_G5/IR_G5 PE0
8	VDDCORE	PWR	VDDCORE power
9	VUSB	PWR	VUSB power input
10	VDDIO	PWR	VDDIO power output
11	VBAT	PWR	VBAT power input
12	LX	PWR	Buck inductor connect pin
13	DGND	GND	Digital Ground
14	VDDBT	PWR	BT power
15	PB2	I/O	ADC4 AUXR1 SDDAT0-G2 SPI1DO-G3 TX0-G2 TX2-G2 HSTRX-G2 PWM2-T3 PB2
16	PB1	I/O	ADC3 FM/AM-G1 AUXL1 SDCLK-G2 SPI1CLK-G3 RX0-G2 RX2-G2 HSTRX-G7 FMOSC-G4 PWM1-T3 TMR3CAP_G4/IR_G4 PB1
17	PB0	I/O	FM/AM-G0 SPDIF2 SDCMD-G2 SPI1DI-G3 FMOSC-G3 PWM0-T3 TMR3CAP_G3/IR_G3 PB0
18	PWRKEY	A	Power key input
19	OSC32KO	A	32K OSC output
20	OSC32KI	A	32K OSC input
21	BT_RFGND	GND	BT RF Ground
22	BT_ANT	A	BT ANT
23	BT_RFGND	GND	BT RF Ground
24	BT_AVDD	PWR	BT RF Power
25	BT_OSCI	A	26M OSC input
26	BT_OSCO	A	26M OSC output
27	USB_DM	I/O	ADC6

			USB DM SPI0CLK-G3 RX0-G3 PB4
28	USB_DP	I/O	ADC5 USB DP SPI0DO-G3 TX0-G3 PB3
29	PA7	I/O	ADC2 AUXR0 SDDAT0-G1 SPI1DO-G2 TX0-G1 TX1-G1 HSTRX-G1 PWM2-T4 PA7
30	PA6	I/O	ADC1 AUXL0 SDCLK-G1 SPI1CLK-G2 RX0-G1 RX1-G1 HSTRX-G6 FMOSC-G2 PWM1-T4 TMR3CAP_G2/IR_G2 PA6
31	PA5	I/O	ADC0 SDCMD-G1 SPI1DI-G2 FMOSC-G1 PWM0-T4 TMR3CAP_G1/IR_G1 PA5
32	PA4	I/O	SPI1DO-G1 TX1-G2 IISMCLK-G1 PA4
33	PA3	I/O	SPI1CLK-G1 RX1-G2 LPWM3-G3 IISLRCLK-G1 PA3
34	PA2	I/O	SPI1DI-G1

			LPWM2-G3 IISCLK-G1 PA2
35	PA1	I/O	SPDIF1 SPI1CLK-G1 TX0-G5 HSTRX-G5 LPWM1-G3 IISDO-G1 PA1
36	PA0	I/O	SPDIF0 RX0-G5 HSTRX-G10 LPWM0-G3 IISDI-G1 PA0
37	PF2/MICL	I/O	ADC10 MICL SPI1DO-G5 TX0-G7 LPWM3-G2 PF2
38	PF1	I/O	AUXR3 SPI1CLK-G5 PF1
39	PF0	I/O	AUXL3 SPI1DI-G5 PF0
40	MICR	A	MICR
41	DACR	A	DAC R
42	DACL	A	DAC L
43	VDDDAC	PWR	DAC power
44	VCM	PWR	DAC VCM
45	AGND	GND	DAC Ground
46	FM_GND	GND	FMRX Ground
47	FM_ANT	A	FMRX ANT
48	PE7	I/O	ADC9 AUXR2 SDDAT0-G3 SPI1DO-G4 TX0-G4 HSTRX-G4 LPWM3-G1 TMR4CAP_G1/IR_G8 PE7

Note: I/O: Digital input/output; I : Digital input; A : Analog Pin; PWR: Power Pin; GND: Ground.

3 Characteristics

3.1 PMU Parameters

Table 3- 1 PMU voltage input Parameters

Sym	Characteristics	Min	Typ	Max	Unit	Conditions
VUSB	Charger Voltage input	3.0	5.0	5.5	V	
VBAT	Voltage input	3.0	3.7	5.0	V	

Table 3- 2 3.3V LDO Parameters

Sym	Characteristics	Min	Typ	Max	Unit	Conditions
VDDIO	3.3V LDO voltage output	-	3.3	-	V	Light Loading condition
Δ VVDDIO	Output Mismatch 1-sigma	-	56	-	mV	VDDIO=3.3v
ILOAD	Maximum output current	-	-	150	mA	@VBAT=3.6v
ISC	Short Circuit Current Limit	-	-	300	mA	@VBAT=3.8v

Table 3- 3 1.6V LDO Parameters

Sym	Characteristics	Min	Typ	Max	Unit	Conditions
VDDBT	1.6V LDO voltage output	-	1.6	-	V	Light Loading condition
Δ VVDDBT	Output Mismatch 1-sigma	-	27	-	mV	VDDBT=1.6v
ILOAD	Maximum output current	-	-	100	mA	@VBAT=3.0v
ISC	Short Circuit Current Limit	-	-	200	mA	@VBAT=3.8v

Table 3- 4 1.2V LDO Parameters

Sym	Characteristics	Min	Typ	Max	Unit	Conditions
VDDCORE	1.2V LDO voltage output	-	1.2	-	V	Light Loading condition
Δ VVDDCORE	Output Mismatch 1-sigma	-	20	-	mV	VDDCORE=1.2v
ILOAD	Maximum output current	-	-	80	mA	@VBAT=3.6v
ISC	Short Circuit Current Limit	-	-	120	mA	@VBAT=3.8v

3.2 IO Parameters

Table 3- 5 I/O Parameters

GPIO—Electrical Characteristics							
Symbol	Description	Related GPIO	Min	Typical	Max	Units	Conditions
V _{IL}	Low-level input voltage		-0.3		1.27	V	VDDIO=3.3V
V _{IH}	High-level input voltage		2.03		3.6	V	VDDIO=3.3V
Driver Ability 1	Output Driver Ability 1			32		mA	VDDIO=3.3V
Driver Ability 0	Output Driver Ability 0			8		mA	VDDIO=3.3V
R _{PUP0}	Internal pull-up resistor 0		8	10	12	K Ω	
R _{PUP1}	Internal pull-up resistor 1		0.24	0.3	0.36	K Ω	
R _{PUP2}	Internal pull-up resistor 2		160	200	240	K Ω	
R _{PDN0}	Internal pull-down resistor 0		8	10	12	K Ω	
R _{PDN1}	Internal pull-down resistor 1		0.24	0.3	0.36	K Ω	
R _{PDN2}	Internal pull-down resistor 2		160	200	240	K Ω	

3.3 Audio DAC Parameters

Table 3- 6 Audio DAC Parameters

Sym	Characteristics	Min	Typ	Max	Unit	Conditions
SNR		-	96	-	dB	VCM cap=1uF VDDDAC cap=1uF with A-wt filter Output -3dBV Fin=1KHz
THD+N		-	-86	-	dB	VCM cap=1uF VDDDAC cap=1uF with A-wt filter Output -3dBV with 10K loading Fin=1KHz
Output Range	Maximum output voltage	-	2.6		V _{peak-peak}	32ohm Loading

3.4 Audio ADC Parameters

Table 3- 7 Audio ADC Parameters

Sym	Characteristics	Min	Typ	Max	Unit	Conditions
SNR		-	90	-	dB	VCM cap=1uF VDDDAC cap=1uF with A-wt filter Input sine amplitude, 850mV RMS Fin=1KHz
THD+N		-	-87	-	dB	VCM cap=1uF VDDDAC cap=1uF with A-wt filter Input sine amplitude, 850mV RMS Fin=1KHz.
Input Range	Input sine wave peak amplitude	0		VCM	V	From aux input, aux 0db gain, VCM represent VCM voltage.

3.5 BT Parameters

Table 3- 8 BT Parameters

Characteristics	Min	Typical	Max	Unit	Conditions
Maximum Transmit Power	-	-	7	dBm	
RMS DEVM	-	5.5	-	%	Maximum TX power 2-DH5 packet
Peak DEVM	-	12.5		%	
EDR Relative Transmit Power		-0.2		dB	
Sensitivity @ Basic Rate		-90.5		dBm	BER=0.1%, using DH5 packet
Sensitivity @ EDR		-89.5		dBm	BER=0.01%, using 2-DH5 packet

3.6 Current Parameters

Table 3- 9 Current Parameters

Sym	Characteristics	Min	Typ	Max	Unit	Conditions
IRTC	RTC mode current	-	4	-	uA	4.2V input, room temp.
Sleep	Sleep current	-	500	2000	uA	3.3V input, room temp

4 Package Information

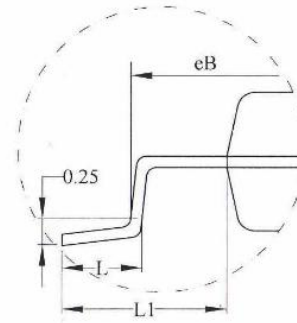
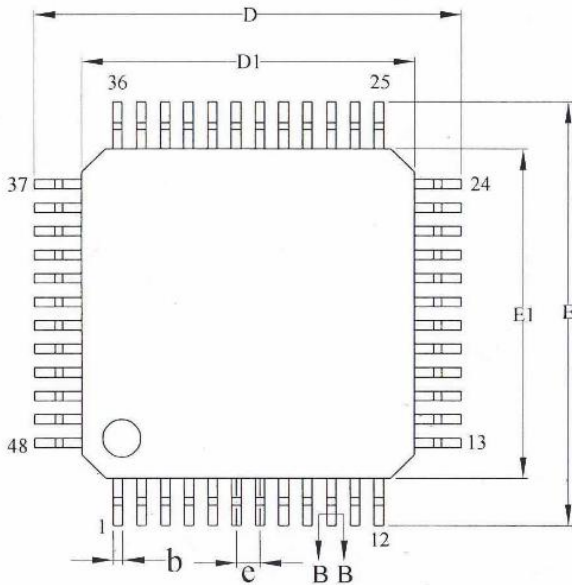
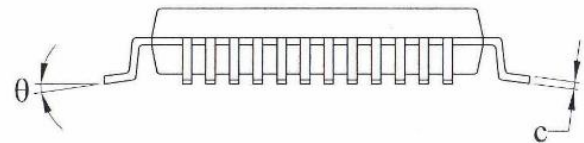
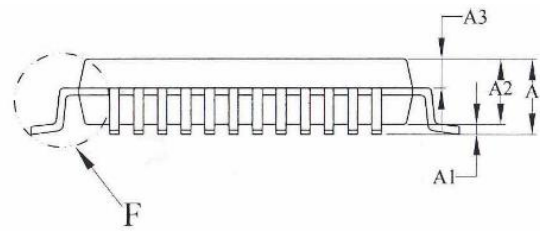

DETAIL: F

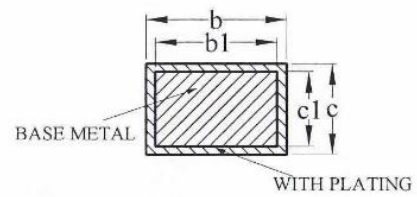

SECTION B-B

SYMBOL	MILLIMETER		
	MIN	NOM	MAX
A	—	—	1.60
A1	0.05	—	0.15
A2	1.35	1.40	1.45
A3	0.59	0.64	0.69
b	0.18	—	0.26
b1	0.17	0.20	0.23
c	0.13	—	0.17
c1	0.12	0.13	0.14
D	8.80	9.00	9.20
D1	6.90	7.00	7.10
E	8.80	9.00	9.20
E1	6.90	7.00	7.10
eB	8.10	—	8.25
e	0.50BSC		
L	0.40	—	0.65
L1	1.00REF		
θ	0	—	7°